



CONVENTIONAL AIR CAP AND FLUID NOZZLE CHART

MODEL NO.	AIR CAPS	Press / Siphon	*SUGGESTED GUN INLET PRESS.	FAN CONTROL	SCFM	AIR CAP RING	AVAILABLE FLUID NOZZLES	NEEDLES / marking on needle
P200Z	22-2064T	pressure	80	60-1500	22	included	32-2118 1.8mm (.070")	40-1218 (218)
							32-2118Z 1.8mm (.070")	
							32-2122 2.2mm (.086")	
							32-2122Z 2.2mm (.086")	
	22-2062T	pressure	80	19	32-0628 2.8mm (.110")**	40-1228 (228)		
				32-2128Z 2.8mm (.110")				

*Gun inlet pressures may vary as required by application

**Only listed fluid nozzle 32-0628 requires item number 3 (See page 3 for details)

Operation and Maintenance Instructions for *P200Z* Spray Guns

Operation

1. Connect air supply hose at handle of gun.
2. Connect a pressurized fluid supply or paint siphon cup to the gun fluid inlet.
3. Fluid flow can be controlled using the fluid control knob, this restricts flow by limiting needle travel. It is best to control fluid flow by proper selection of fluid orifice size and use the fluid control knob to “fine tune flow rate”.
4. Fan width can be adjusted using the fan control knob. Turning the knob clockwise narrows the fan.

Maintenance

IMPORTANT! Routine cleaning and maintenance is essential to insure proper gun operation.

Several states prohibit spraying solvent into the atmosphere and require the use of covered gun cleaner.

1. If a gun cleaner is being used, connect and clean the gun in the gun cleaner according to the manufactures instructions.
2. If a gun cleaner is not being used:
Remove air cap and clean separately using clean solvent.
For pressure setups, connect a pressurized solvent supply to the fluid inlet, trigger the gun allowing solvent to flow thru the gun until clean.
For siphon setups, first clean the siphon cup thoroughly then spray clean solvent thru the gun until clean.

NOTE: Gun head disassembly is not recommended for normal cleaning and maintenance.

Gun head disassembly and reassembly instructions:

Have repair kit # 10-108 available before gun disassembly.

Gun head disassembly

To remove the nozzle carrier (5) and air cap adapter (6):

1. Remove the air cap (1), fluid nozzle tip (2), fluid nozzle body (3), and needle (13).
2. Remove the needle seal cartridge (23).
3. Loosen the locknut (9) and remove fluid inlet (10) using a 5/8” open-end wrench.
4. The nozzle carrier (5) and air cap adapter (6) will now slide forward from the gun body (11).

Gun head reassembly

1. Install a new o-ring (7) on the air cap adapter (6).
2. Install o-ring (4) between fluid nozzle body (3) and fluid nozzle carrier (5).
3. Install the thread locknut (9) onto the fluid inlet (10) as far as possible.
4. Install a new fluid inlet seal (8) into the recess area on the nozzle carrier (5) inlet port.
5. Slide the nozzle carrier (5) into air cap adapter (6) and insert into the gun body (11) as far as possible. Be sure the nozzle carrier (5) extends into the hole at the back of the gun head. Install the needle seal (23) but do not tighten.
6. Rotate the nozzle carrier (5) until the fluid inlet port in the nozzle carrier (5) is aligned with the threaded hole in the body. While in this position, insert the fluid inlet (10) and tighten firmly.
7. Tighten the needle seal (23) to approx. 12 ft.-lb. torque.
8. Tighten the fluid inlet (10) to approx. 25 ft.-lb. torque.
9. Tighten the locknut (9) to approx. 33 ft.-lb. torque.

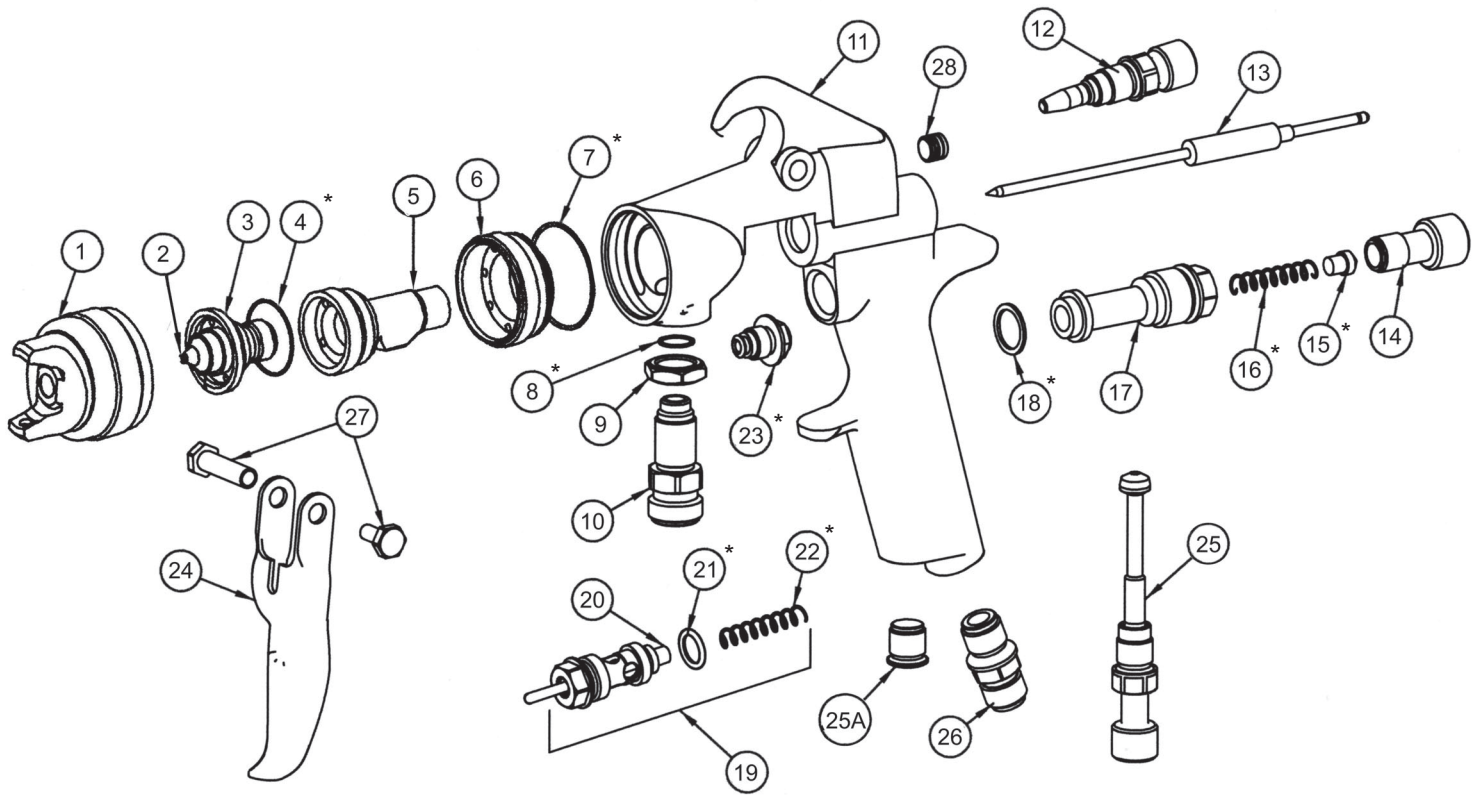

ITEM NO.	PART NO.	DESCRIPTION	ITEM NO.	PART NO.	DESCRIPTION
1	See Air Cap Chart	Air Cap**	16	60-206	Needle Return Spring (HD)*
2	See Air Cap Chart	Fluid Nozzle Tip**	17	60-201	Rear Bushing
3	32-2201	Fluid Nozzle Body**	18	60-119	Seal*
4	98-8020	Gasket*	19	60-1520	Air Valve Assembly
5	60-L21C	Nozzle Carrier	20	60-302	Air Valve Poppet
6	60-22	Air Cap Adapter	21	60-125	O-Ring*
7	60-131	O-Ring*	22	61-1003	Air Valve Spring*
8	60-124	Fluid Inlet Seal	23	60-1402	Needle Seal Cartridge*
9	60-128	Locknut	24	60-2101	Trigger
10	60-126	Fluid Inlet Fitting	25	60-1510	Air Control
11	60-1125	Panther Gun Body Conventional	25A	60-122	Plug (optional)
12	See Air Cap Chart	Fan Control Assembly**	26	60-104	Air Inlet Fitting
13	See Air Cap Chart	Fluid Needle**	27	60-1033	Trigger Pivot Set
14	60-202	Fluid Control Knob	28	98-0109	Allen Plug
15	60-209	Spring Seat*			

**See air cap selection chart on page 1

*Indicates part included in repair kit # 10-108

