



WIWA HERKULES GX SERIES

WIWA HERKULES GX SERIES

The **WIWA HERKULES GX SERIES** consists of paint spraying units particularly suited for large areas and thick film coatings where extremely high pressure ratios and high volume output are required.

The **WIWA HERKULES 270 GX** is a dynamic and powerful supplement to our single feed product range, providing the highest pressure ratio: 88:1, while the **WIWA HERKULES 333 GX**, our latest addition, with its biggest and most powerful air motor yet, provides the highest output at a given pressure ratio.

The new technology oil – free, low noise, anti – icing air motors not only provide an improved work environment; with their enormous output, these units can – without pulsation – easily feed multiple guns with hoses longer than 100 meters. The units are suitable for continuous operation in the toughest conditions and ideal for automated spraying and paint circulation systems.

The units are made of the highest quality materials. All parts in contact with the material are made of stainless steel and are crafted to require the lowest possible maintenance, which makes the series highly durable and very economical.

THE WIWA HERKULES GX SERIES COMES WITH:

- a stable, multi-functional frame, including ring bolts for easy lifting
- self-adjusting packings (resulting in reduced wear and tear and lower maintenance costs)
- a QR code on the machine for quick access to the device's technical data
- a hook spanner for the coarse thread, easy-to-open material pump and high pressure filter

WIWA HERKULES 270 GX (previously AIRLESS 270)

WIWA HERKULES 333 GX

TECHNICAL DATA	Model 270088	Model 270071	Model 270049	Model 270037	Model 270024	Model 333075	Model 333057	Model 333037
Pressure Ratio	88:1	71:1	49:1	37:1	24:1	75:1	57:1	37:1
Max. free flow output at 60 cycles (l/min.)	9,2	11,3	16,5	21,6	33,0	16,5	21,6	33
Output per cycle (ccm)	153	189	275	360	550	275	360	550
Max. air inlet pressure (bar)	5,5	7	8	8	8	6,5	7	8
Max. operating pressure (bar)	484	497	392	296	192	487	399	296
Air motor piston diameter (mm)	270	270	270	270	270	333	333	333

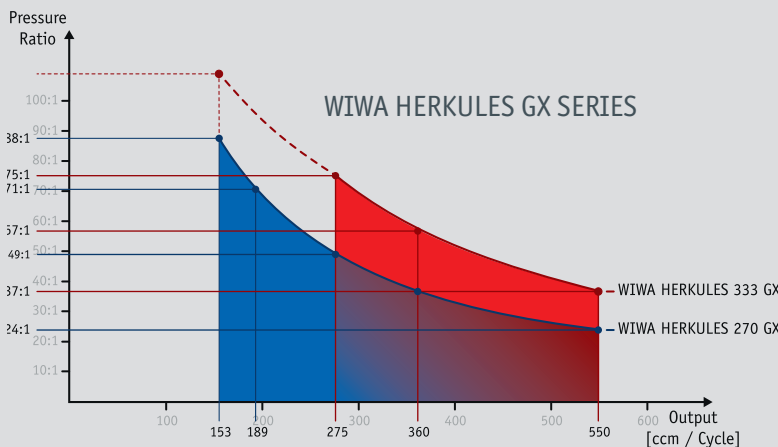

The graph shows the different output values at the given pressure ratios for each pump.

The **WIWA HERKULES 333 GX** will provide a higher output at the same pressure ratio.

Headoffice and Production | WIWA Wilhelm Wagner GmbH & Co. KG | D-35633 Lahnau | www.wiwa.com

WIWA Partnership USA | WIWA LP | 107 N. Main St. | P.O. Box 398 Alger, OH 45812 | www.wiwalp.com

WIWA China | WIWA (Taicang) Co., Ltd. | Taicang City | Jiangsu Province 215400, P.R.China | www.wiwa-china.com

WIWA Middle East General Trading LLC | Jebel Ali Industrial 1 | DUBAI, United Arab Emirates | www.wiwa-middleeast.com

WIWA®

because it works



PROFESSIONAL / HERKULES

WWW.WIWA.COM

PROFESSIONAL + HERKULES – AIRLESS HIGH PERFORMANCE UNITS



WIWA PROFESSIONAL



WIWA HERKULES

New standards for
efficiency and
performance under
extreme conditions

WIWA is globally renowned through its premium-quality, robust pumps for all areas of application. The equipment in the PROFESSIONAL and HERKULES series is setting new standards for efficiency and performance. It particularly highlights its strengths in the toughest of everyday uses, e.g. for large surface coverage and thick coatings in the marine, offshore and pipe coating industries or for structural and corrosion protection. However, high performance also means the highest demands on all components.

This is where WIWA's long standing global experience comes to bear; premium quality materials, a sophisticated design and precise manufacturing make the equipment in the PROFESSIONAL and HERKULES series durable and easy to service. All Airless paint spraying units in the PROFESSIONAL and HERKULES series are also available as, or can be converted into Hot Job spraying units or Air Combi units for finer finishes. These pumps are pneumatically driven and rated explosion proof. Let WIWA's 60+ years of experience work for you!

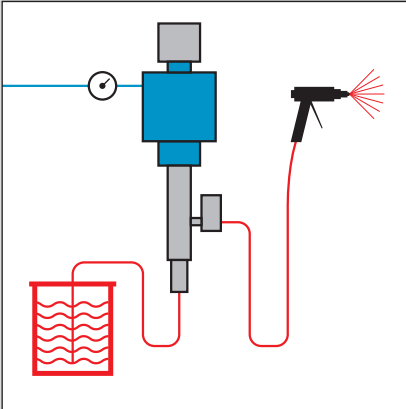

WIWA PROFESSIONAL and HERKULES, available as Airless spraying units

AIRLESS

High pressure

Economical, environmentally friendly spraying method with excellent surface area coverage at high pressures.

The high pressure pump draws the spraying agent from any desired container and transfers it to the spray gun under high pressure via a high pressure hose.

Fine, airless atomisation is achieved through a specially designed spray nozzle. The spray jet is directed onto the material at high speed, thereby providing an optimal finish.

The benefits at a glance:

- Effective painting and coating of large surfaces
- Higher coating thickness in just one pass
- Saves materials and solvent
- Closed, uniform spray pattern
- Better use of energy due to minimal air consumption
- Environmental friendly as no spray mist when correctly configured

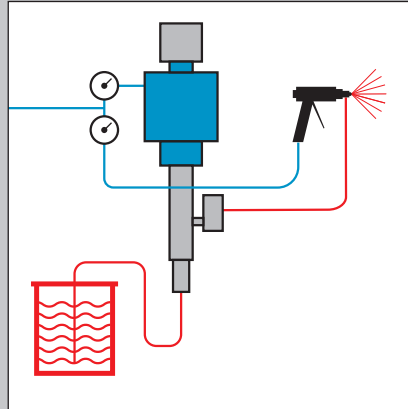

WIWA PROFESSIONAL, available as Air Combi finishing systems for painting lines and paint circulation systems

AIR COMBI

Air-assisted painting

The Air Combi combines the advantages of Airless and conventional spraying techniques.

Using this painting method, the spraying agent is transferred to the spray gun under moderate pressure and pre-atomised. The fine spray distribution is achieved by applying regulated compressed air as the paint is discharged. A soft, controllable spray jet is produced with minimum paint mist.

Ideal for highly refined painting tasks on large surface areas as well as for angular components and shaped or small workpieces.

The benefits at a glance:

- The finest atomisation generates first class finishes
- High material savings
- Soft, controllable spray pattern
- Low operating costs due to minimal air consumption
- Low pump wear due to low material pressure
- Environmentally friendly due to minimal overspray

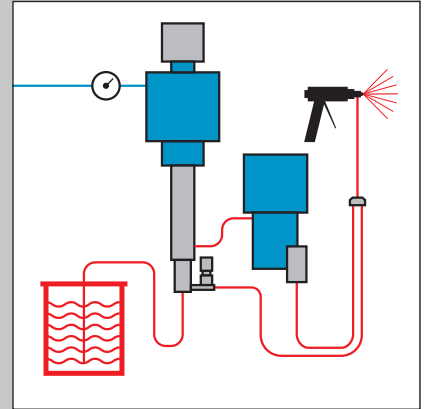

WIWA PROFESSIONAL and HERKULES, also available as Hot Job units with integrated fluid heater

HOT SPRAYING SYSTEMS

WIWA Hot Job systems for high film builds, short drying times, highest surface quality and extremely viscous coating materials.

During the hot spray process, the material is heated to the desired spraying temperature using the WIWA material flow heater.

This eliminates the need to use solvents to lower the viscosity.

An adjustable circulation system maintains a constant material temperature providing even coating and high finish quality.

The benefits at a glance:

- Highly viscous materials can be effortlessly processed
- High film builds
- Short drying periods
- Excellent surface coverage
- Glossier surfaces due to improved paint dispersion
- Environmentally and user friendly as no solvents are required

Existing Airless spraying units can be converted into the Air Combi system.

PROFESSIONAL – AIRLESS AND AIRLESS HOT SPRAYING IN THE HIGH



The art of
simplification
perfected:

WIWA PROFESSIONAL

WIWA Airless paint spraying units from the PROFESSIONAL series particularly demonstrate their strengths during the toughest use. This is guaranteed by their impressive, globally renowned durability. Spare parts enquiries are still received for units that are more than 20 years old, with most of these parts still being available. Could there be any better argument?

The simplest solution is the best. However, the demands on items that are 'brilliantly simple' are enormous. Original WIWA Airless paint spraying units from the PROFESSIONAL series fulfill the high demands placed on simple solutions thanks to the years of experience of our development and production teams, carefully selected, high quality materials and our own production technology with the highest demands for perfection. Global recognition is also given to the return on investment during everyday use in the shipbuilding industry, the marine and offshore industry, the steelwork and bridge industry, pipe line construction and other areas of application of heavy-duty corrosion protection and multiple gun applications.



Standard high pressure filter on the pump outlet



Maintenance unit

PERFORMANCE CLASS

THE ADVANTAGES OF THE PROFESSIONAL SERIES

- Dual action pump with long stroke and fixed packings.
- Maintenance free, low noise compressed air motor.
- Thorough cleaning through an innovative flushing system.
- A closed lubrication chamber separates the air motor and the material pump. The lubricant prevents paint from drying onto the piston rod and protects the packings.
- Large valve and material passages make processing highly viscous materials simple.
- Pre-tensioned, self adjusting packings reduce wear and tear and lower maintenance costs.
- Above-average service life due to hard chromed dual pistons, carbide faced valve plates and stainless steel valve balls.
- Dual filter system prevents downtime.
- The air motor is largely prevented from freezing by the standard, integrated air maintenance unit.
- Efficient use through the simultaneous feeding of several spray guns, depending on the nozzle size and the viscosity of the coating material.
- Environmentally friendly thanks to noise levels being kept to a minimum by the optimised control system and the large muffler.
- Perfect surfaces and larger area coverage.
- The low number of components makes maintenance simple.



PROFESSIONAL

PROFESSIONAL – CONFIGURATION OPTIONS

PROFESSIONAL pumps for highly viscous coating materials								
Model	24071		28064		24053		28048	
Max. free-flow output	24 l/min		28 l/min		24 l/min		28 l/min	
Pressure ratio	71:1		64:1		53:1		48:1	
Pump capacity per double stroke	138 cm ³		153 cm ³		138 cm ³		153 cm ³	
Max. air inlet pressure	6,5 bar		7 bar		8 bar		8 bar	
Max. permissible operating pressure	460 bar		450 bar		420 bar		380 bar	
Piston diameter of the air motor	230 mm		230 mm		200 mm		200 mm	
Piston stroke of the air motor	120 mm		120 mm		120 mm		120 mm	
Version	N	R	N	R	N	R	N	R
Pump with cart and maintenance unit (compact)	0639061	0639180	0639063	0639184	0639279	0639282	0639285	0639288
Pump on lift cart with maintenance unit (compact)	0640057	0640058	0640018	0640017	0640055	6490056	0640059	0640060
Pump with wall mount and maintenance unit (compact)	0639062	0639181	0639064	0639185	0639280	0639283	0639286	0639289

PROFESSIONAL pumps for medium and low-viscosity coating materials, automated spray and fluid circulation												
Model	38042		44032		38032		24026		44024		28023	
Max. free-flow output	38 l/min		44 l/min		38 l/min		24 l/min		44 l/min		28 l/min	
Pressure ratio	42:1		32:1		32:1		26:1		24:1		23:1	
Pump capacity per double stroke	235 cm ³		306 cm ³		235 cm ³		138 cm ³		306 cm ³		153 cm ³	
Max. air inlet pressure	8 bar		8 bar		8 bar		8 bar		8 bar		8 bar	
Max. permissible operating pressure	335 bar		255 bar		255 bar		210 bar		190 bar		185 bar	
Piston diameter of the air motor	230 mm		230 mm		200 mm		140 mm		200 mm		140 mm	
Piston stroke of the air motor	120 mm		120 mm		120 mm		120 mm		120 mm		120 mm	
Version	N	R	N	R	N	R	N	R	N	R	N	R
Pump with cart and maintenance unit (compact)	0639301	0639304	0639313	0639316	0639307	0639310	0643189	0643190	0639319	0639322	0643191	0643192
Pump on lift cart with maintenance unit (compact)	0640065	0640066	0640069	0640070	0640063	0640064	–	–	0640067	0640068	–	–
Pump with wall mount and maintenance unit (compact)	0639302	0639305	0639314	0639317	0639308	0639311	0643176	0643177	0639320	0639323	0643178	0643179

Version	38042	44032	38032	24026	44024	28023
Mounting kits for hot spraying units on cart without circulation	0640926	0640926	0640926	0630498	0640926	0630498
Mounting kits for hot spraying units on wall mounts without circulation	0640929	0640929	0640929	0630525	0640929	0630525
Mounting kits for hot spraying units on cart with circulation	0640078	0640078	0640078	0629398	0640078	0629398
Mounting kits for hot spraying units on wall mounts with circulation	0640928	0640928	0640928	0630531	0640928	0630531

Scope of delivery of the mounting kits: WIWA 3500 material flow heater with backflow regulator, temperature display and all necessary connection hoses and attachments

Spray accessory kit no. 05 for the `ready-to-spray` version
Order no. 0621676 comprising:

- WIWA 500 D Airless spray gun (with swivel joint)
- NW 6 material hose (600 bar, 1/4", 15 m),
- REV-GUARD™ reversible guard with nozzle 627

Spray accessory kit no. 07 for the `ready-to-spray` version for hot spraying units in the N and R versions:
Order no. 0621935 comprising:

- WIWA 500 F Airless spray gun (with swivel joint)
- 2 x NW 6 material hose (410 bar, 7.5m)
- 1 x NW 4 material hose (410 bar, 1.0 m)
- Manifold 3 x 1/4"
- Standard nozzle 40° – 0.53 mm

Spray accessory kit no. 12 for the `ready-to-spray` version
Order no. 0640932 comprising:

- WIWA 500 F Airless spray gun
- NW 10 material hose (500 bar, 3/8", 15m)
- NW 6 material hose (600 bar, 1/4", 7.5 m)
- REV-GUARD™ reversible guard with nozzle 627

We recommend our special versions with an open system for glassflake materials.

N = Mild steel version R = Stainless steel version

DESIGN FEATURES OF THE PROFESSIONAL SERIES

Air motor:

- 1 The low number of components makes the motor easy to assemble and disassemble.
- 2 The toggles are clearly visible and thus easy to install.
- 3 Pulsation is barely noticeable thanks to the high stroke change-over speed.
- 4 Pressure ratio can be varied by changing the air motor piston diameter.

Lubrication chamber

- 5 A closed lubrication chamber separates the air motor and the material pump. The closed design prevents foreign objects such as blasting material from entering the pump system from the outside. The lubricant also prevents paint from drying onto the piston rod and protects the packings.

Material pump:

- 6 The pump components are quick to assemble and disassemble as they are simply connected by union nuts or by being screwed together.
- 7 Sealing rings located in front of the threads prevent the threads from sticking and make disassembly easier.
- 8 Precision bushings ensure simple and exact alignment of components and thus less wear and tear.
- 9 Large openings and voluminous fluid passages reduce pressure loss.
- 10 Better flushing due to large fluid passages and short packing tension springs.
- 11 The displacement and pressure ratio can be changed by exchanging the piston rod and packings.

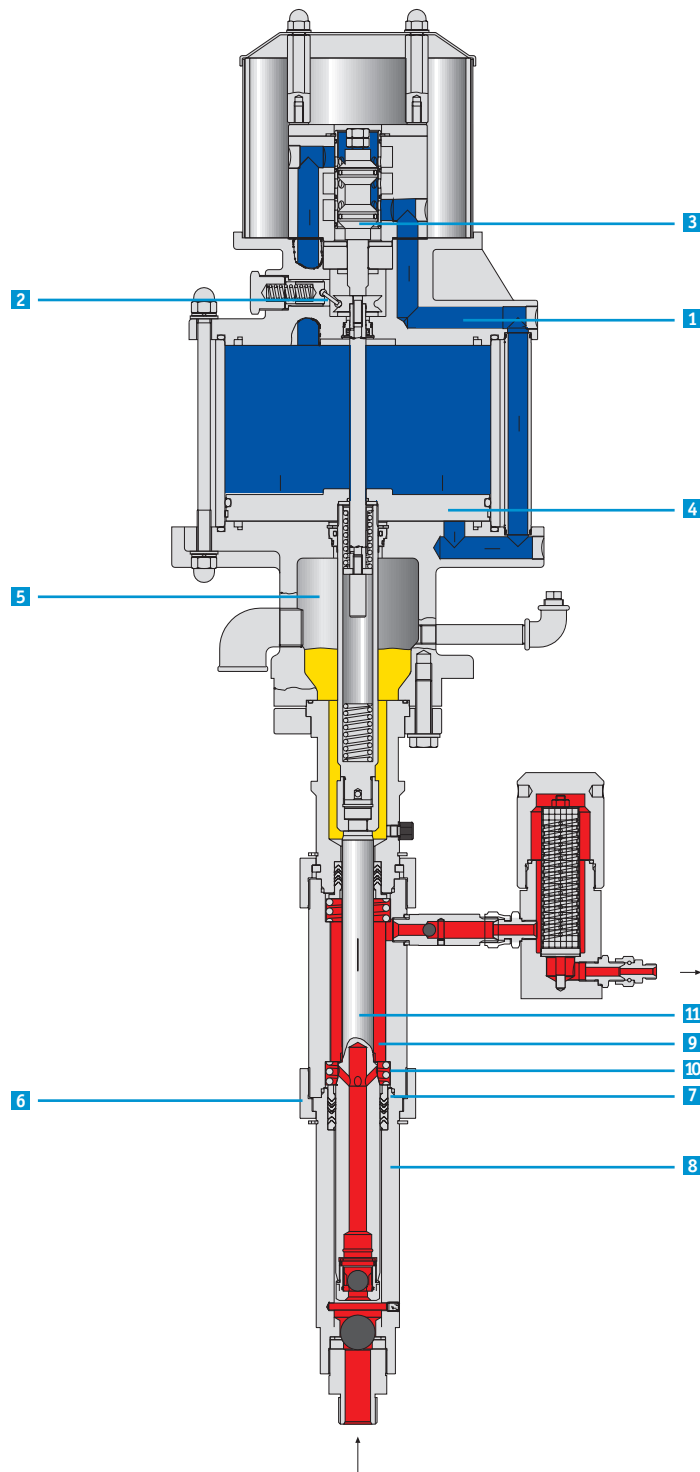

PROFESSIONAL

PROFESSIONAL – AREAS OF APPLICATION



We recommend	PROFESSIONAL PUMPS for highly viscous coating materials				PROFESSIONAL pumps for medium and low-viscosity coating materials, automated spray and fluid circulation					
Model	24071	28064	24053	28048	38042	44032	38032	24026	44024	28023
Max. free-flow output	24 l/min	28 l/min	24 l/min	28 l/min	38 l/min	44 l/min	38 l/min	24 l/min	44 l/min	28 l/min
Pressure ratio	71 : 1	64 : 1	53 : 1	48 : 1	42 : 1	32 : 1	32 : 1	26 : 1	24 : 1	23 : 1
Pump capacity per double stroke	138 cm ³	153 cm ³	138 cm ³	153 cm ³	235 cm ³	306 cm ³	235 cm ³	138 cm ³	306 cm ³	153 cm ³

Areas of application										
Large surfaces	●	●	●	●	●	●	●	●	●	●
Ship painting	●	●	●	●	●	●	●	○	○	○
Steel and hall construction	●	●	●	●	●	●	●	○	○	○
Railcar construction	●	●	●	●	●	●	●	●	○	○
Paint and finishing shops	●	●	●	●	●	●	●	○	○	○
Offshore industry	●	●	●	●	●	●	●	○	○	○
Industrial coatings	●	●	●	●	●	●	●	○	○	○
Structural and corrosion protection	●	●	●	●	●	●	●	○	○	○
Insulation	●	●	●	●	●	●	●	●	○	○
Fire prevention	○	○	○	○	●	●	●	–	–	–
Transfer pumps	–	–	–	–	○	○	○	–	●	–

Spraying agent										
Abrasive materials*	○	○	○	●	●	●	●	●	●	●
Flame protection materials	–	○	○	●	●	○	○	–	–	–
Glassflake	●	●	●	●	○	○	○	–	–	–
Insulated and thick-film materials	○	●	○	●	●	○	○	–	–	–
Anti-fouling	●	●	●	●	●	–	–	–	–	–
Cold bitumen	●	●	●	○	○	–	–	–	–	–
Materials with short fibres	●	●	●	○	○	○	–	–	–	–
Low-solvent and solvent-free paints	●	●	●	●	○	○	○	○	–	–
Sprayable paints and varnishes	●	●	●	●	●	●	●	●	●	●
Two component and tar/epoxy paints**	●	●	●	●	●	–	–	–	–	–

● Very suitable ○ Suitable – Unsuitable

* With low to medium viscosity, such as zinc primer, micaceous iron ore, solvent-based zinc silicate
 ** Highly viscous and coarsely pigmented

AREAS OF APPLICATION FOR THE PROFESSIONAL SERIES

- Large surfaces
- Ship building
- Steel and hall construction
- Railcar construction
- Paint and finishing shops
- Offshore industry
- Industrial coatings
- Structural and corrosion protection
- Insulation
- Fire prevention
- Coating and finishing systems

Units with higher pressure ratios

Particularly suited for use with highly viscous, low-solvent and solvent free materials with a high solids content. Optimally suited for larger nozzle bores, long hoses and high pressures. Significant pressure reserves compensate for low or fluctuating air supply pressure

Units with higher displacement and lower pressure ratio

For use with coarsely pigmented or abrasive materials with low to medium viscosity. These units are also particularly suited for use with large tips and multiple spray guns.

Professional units with a lower pressure ratio are also optimally suited for paint supply systems in the Airless or Air-Combi procedures and for circulation lines for supplying paint.



PROFESSIONAL

HERKULES – AIRLESS AND AIRLESS HOT SPRAYING EQUIPMENT



WIWA HERKULES:
maximum performance
and durability
under extreme
conditions

Power, perfection and precision! The globally successful WIWA Airless pump range is achieving new levels of performance with the new WIWA HERKULES series. With pressure ratios of up to 75:1 and outputs of up to 550 cm³ per cycle, WIWA HERKULES pumps are the world's most powerful airless spraying units. Even materials that were previously non-sprayable or only sprayable under certain circumstances can be processed. The high delivery volume and the associated slow piston speed maintain a low level of wear even with large nozzle bores and materials with high solids contents. The extraordinarily high performance data makes the WIWA HERKULES series ideal for use in shipyards and the offshore sector, structural and fire protection, automatic spraying systems and other major projects that require top performance and no downtime.



Standard high pressure filter on the pump outlet



Standard 1" maintenance unit



Low noise thanks to the voluminous muffler

HIGH PERFORMANCE CLASS

THE ADVANTAGES OF THE HERKULES SERIES

- Efficient coating of large surfaces.
- Large area output and high film builds.
- Can be easily operated with hose lengths in excess of 100 m.
- Maximum performance even in the toughest conditions.
- Several spray guns can be used, even with extremely long hoses.
- Large power reserves even if the pressure is low on the compressed air supply network.
- Economical due to the robust unit technology and high durability.
- Quick maintenance due to simple installation.
- Large valve and material passages make processing highly viscous materials simple.
- Self adjusting packings reduce wear and tear and lower maintenance costs.
- Above average service life due to hard chromed dual pistons, tungsten carbide valve seats and stainless steel balls.
- Dual filter system prevents downtime.
- 1" maintenance unit installed as standard.
- Environmentally friendly thanks to noise levels being kept to a minimum by the optimised control system and the large built in muffler.
- Ideal for automated spraying systems and paint circulation systems.



HERKULES

HERKULES – CONFIGURATION OPTIONS

Technical data	for extremely abrasive materials		for medium to highly viscous materials		for coating systems and paint circulation systems	
	35075	35061	48057	48046	60036	60028
Model	35075	35061	48057	48046	60036	60028
Max. free-flow output	35 l/min	35 l/min	48 l/min	48 l/min	60 l/min	60 l/min
Pressure ratio	75:1	61:1	57:1	46:1	36:1	28:1
Pump capacity per double stroke	275 cm ³	275 cm ³	360 cm ³	360 cm ³	550 cm ³	550 cm ³
Max. air inlet pressure	6 bar	7 bar	7 bar	8 bar	8 bar	8 bar
Max. permissible operating pressure	450 bar	427 bar	399 bar	368 bar	288 bar	224 bar
Piston diameter of the air motor	333 mm	300 mm	333 mm	300 mm	333 mm	300 mm
Piston stroke of the air motor	120 mm	120 mm	120 mm	120 mm	120 mm	120 mm
Version	R	R	R	R	R	R
Pump w. cart and R1" maintenance unit (3-piece)*	0641375	0641376	0641377	0641378	0642026	0642025
Pump on lift cart and R1" maintenance unit (3-piece)*	0641729	0641728	0641731	0641730	0642028	0642027
Pump w. wall mount and R1" maintenance unit (3-piece)*	0642037	0642036	0642039	0642038	0642031	0642030
Accessories set for ready-to-spray version	Nr. 05		Nr. 04		Nr. 04	
*3/4" optional R = stainless steel version (RS on request)						
Version	35075	35061	48057	48046	60036	60028
Mounting kits for hot spraying units on cart without circulation	0642222	0642238	0642222	0642222	On request	On request
Mounting kits for hot spraying units on cart with circulation	0642215	0642237	0642237	0642215	On request	On request

Scope of delivery of the mounting kits:

WIWA 3500 material flow heater with backpressure regulator, temperature display and all necessary fittings and attachments.



Spray accessory no. 04

Order no. 0621668 comprising:

- WIWA 500 D Airless spray gun (with swivel joint)
- NW6 material hose (410 bar, 1/4", 15 m)
- Reversible guard with reversible nozzle 627

Spray accessory no. 05

Order no. 0621676 comprising:

- WIWA 500 D Airless spray gun (with swivel joint)
- NW6 material hose (600 bar, 1/4", 15 m)
- Reversible guard with reversible nozzle 627

Accessories

- Suction filter and suction sieve for different pigment sizes. (Accessories)
- Stirrer mounting kit for continuous agitation of zinc materials or other separating fillers (Accessories)
- Hot spraying unit mounting kit
Heating extremely viscous coating materials makes it possible to vastly improve results and reduce solvent use. The WIWA material flow heater is also suitable for use with high ratio pumps. (Accessories)
- WIWA HERKULES with wall bracket
- WIWA HERKULES on lift trolley

DESIGN FEATURES OF THE HERKULES SERIES

Air motor

- 1 The low number of components makes the motor easy to assemble and disassemble.
- 2 The toggles are clearly visible and thus easy to install.
- 3 Minimal pulsation due to short change over time.
- 4 Pressure Ratio can be varied by changing the air motor piston diameter.

Lubrication chamber

- 5 A closed lubrication chamber separates the air motor and the material pump. The closed design prevents foreign objects such as blasting material from entering the pump system from the outside.

The lubricant also prevents paint from drying onto the piston rod and protects the packings.

Material pump

- 6 The pump components are quick to assemble and disassemble.
- 7 Precision guides ensure simple and exact alignment of components and thus less wear and tear.
- 8 Large fluid passages reduce pressure loss.
- 9 Better flushing due to large fluid passages and short packing retention springs.

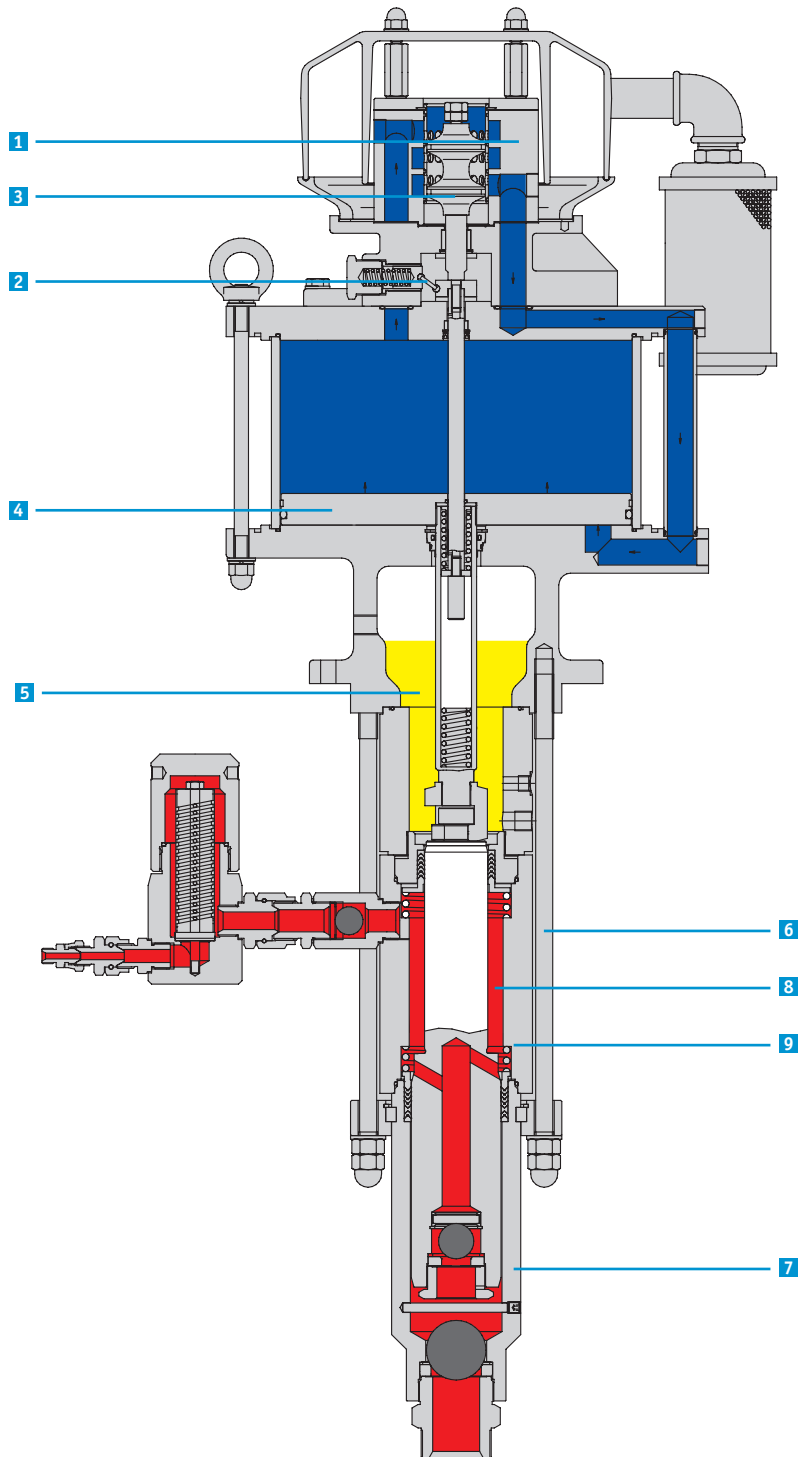

HERKULES

HERKULES – AREAS OF APPLICATION



We recommend						
Model	35075	35061	48057	48046	60036	60028
Max. free-flow output	35 l/min	35 l/min	48 l/min	48 l/min	60 l/min	60 l/min
Pressure ratio	75:1	61:1	57:1	46:1	36:1	28:1
Pump capacity per double stroke	275 cm ³	275 cm ³	360 cm ³	360 cm ³	550 cm ³	550 cm ³
Areas of application						
Fire prevention	○	○	●	●	●	—
Large surfaces	●	●	●	●	●	●
Ship building	●	●	●	●	●	●
Steel and hall construction	●	●	●	●	●	●
Railcar construction	●	●	●	●	●	●
Offshore industry	●	●	●	●	○	—
Industrial coatings	●	●	●	●	●	—
Structural and corrosion protection	●	●	●	●	●	—
Insulation	●	●	●	●	●	○
Paint supply systems	—	—	—	●	●	●
Automated coating systems	●	●	●	●	●	●
Spraying agent						
Glassflake	○	●	●	●	○	—
Anti-foulings	●	●	●	●	○	—
Cold bitumen	●	●	●	○	○	—
Low-solvent and solvent-free paints	●	●	●	○	○	—
Materials with short fibres	—	●	●	●	●	—
Sprayable paints and varnishes	●	●	●	●	●	●
Two component and tar/epoxy paints*	●	●	●	●	○	—
Abrasive materials (zinc silicates and similar)	—	—	○	●	●	●
Flame protection	—	○	●	●	●	—
Insulated high-build materials	—	—	○	●	●	—

● Very suitable ○ Suitable — Unsuitable

* highly viscous and coarsely pigmented

THE AREAS OF APPLICATION OF THE HERKULES SERIES

- Fire preventions
- Large surfaces
- Ship building
- Steel and hall construction
- Railcar construction
- Offshore industry
- Industrial coatings
- Structural and corrosion protection
- Insulation
- Paint supply systems
- Automated coating systems

WIWA HERKULES 35075 and 35061

The enormous pressure ratios make both of these models particularly suited for use with extremely viscous and solvent free materials with a high solids content. Significant pressure reserves compensate for low or fluctuating air supply pressure.

WIWA HERKULES 48057 und 48046

The higher output makes these units suitable for use with coarsely pigmented and abrasive materials or with fibre-filled coating materials with a medium to high viscosity.

WIWA HERKULES 60036 und 60028

The enormous output of 550 cm³ per double stroke makes these units ideal for use in multiple gun (automated or manual) spraying systems. They are also well suited for paint circulation systems and can be used for both Airless and Air-Assisted Airless applications

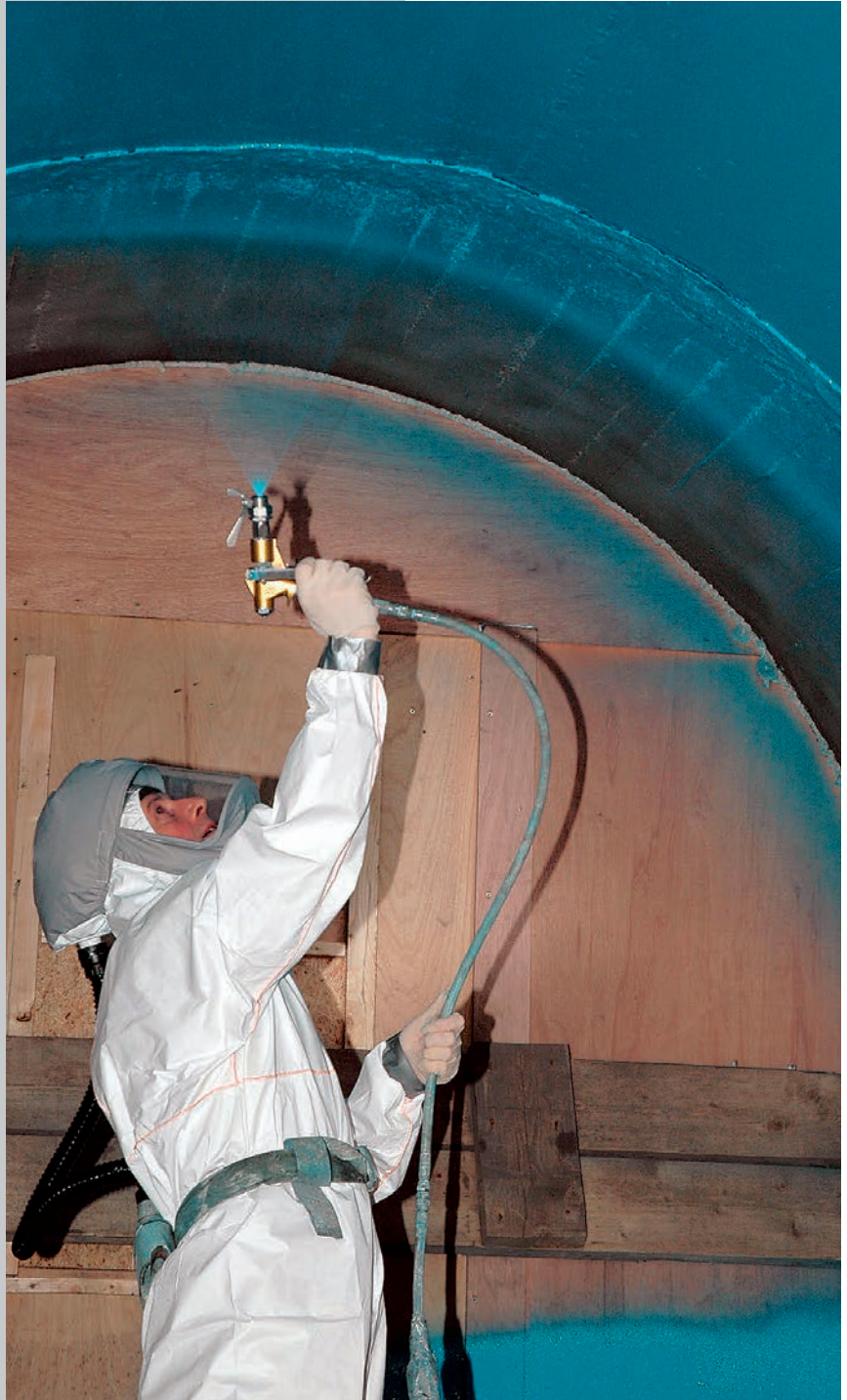

HERKULES

PRODUCT RANGE EXAMPLES

**ATEX 94/9/EG****Headquarters and Production**

WIWA Wilhelm Wagner GmbH & Co. KG
 35633 Lahnuau, Germany
 Phone: +49 (0) 6441 609-0

www.wiwa.com**WIWA Partnership USA**

WIWA LP
 107 N. Main St.
 P.O. Box 398, Alger, OH 45812
 Phone: +1-419-757-0141
 Toll Free: +1-855-757-0141

www.wiwalp.com**WIWA Subsidiary China**

WIWA (Taicang) Co., Ltd.
 Taicang City
 Jiangsu Province 215400, P.R.China
 Phone: +86-512-53548857

www.wiwa-china.com**WIWA Middle East General Trading LLC**

Jebel Ali Industrial 1
 DUBAI, United Arab Emirates
 Phone: +9714-884-8220

www.wiwa-middleeast.com

WIWA FLEXIMIX Electronic 2K
 Paint Spraying and Coating Equipment



WIWA Fluid Transfer Pumps
 for diverse applications



WIWA DUOMIX Plural Component Airless
 Paint Spraying Equipment



WIWA Airless, Air-Combi
 and Hot Spraying Systems



WIWA POWERPACK XXL 2K
 Hydraulic Systems



WIWA PU 460
 Polyurea Systems